

型号

工作电流
引弧方式
喷嘴冷却方式
电极冷却方式
冷却水进入压力
冷却水进入温度
喷嘴孔径范围
电极直径



TX-3

50-500 A
高频
直接水冷
间接水冷
0.4-0.8 MPa
不高于 45℃
2.4-4.8 mm
4.8 mm

Model

Current Range
Art Starting
Nozzle Cooling
Electrode Cooling
Water-in Pressure
Water-in Temperature
Nozzle Aperture
Electrode Dia.

TX-3

50-500 A
High Frequency
Direct
Indirect
0.4-0.8 MPa
< 45℃
2.4-4.8 mm
4.8 mm

等离子焊枪

■ Plasma Arc Welding Torch

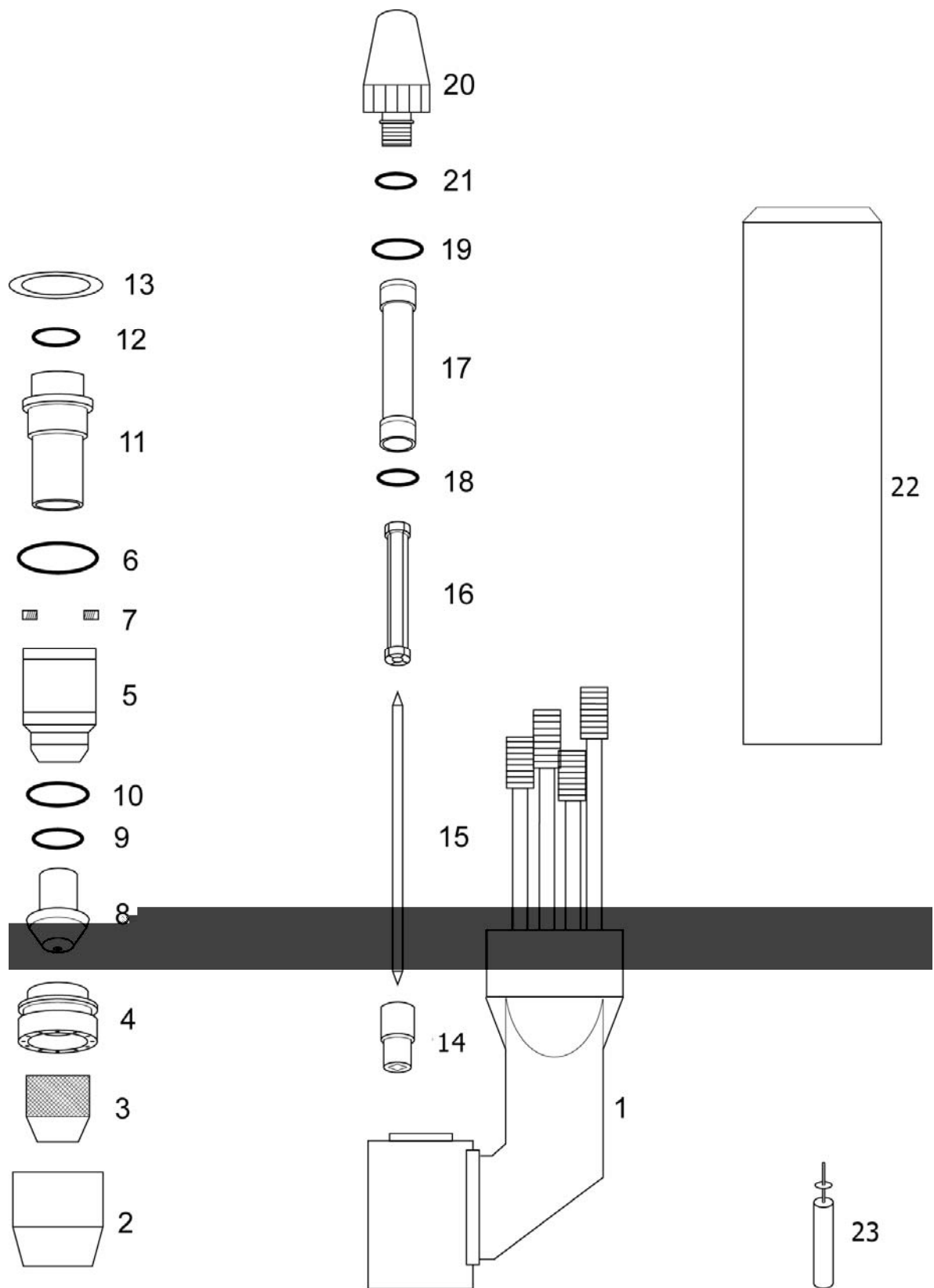

序号	订货号	产品描述	Description
1	83180	TX-3 焊枪本体 (180 度)	TX-3 Torch Body, 180 deg.
1	83181	TX-3 焊枪枪头总成 (180 度)	TX-3 Torch Head Assembly, 180 deg.
1	83182	TX-3 焊枪枪头总成 (180 度)	TX-3 Torch Assembly, 180 deg.
2	83300	TX-3 保护罩(陶瓷)	TX-3 Shield Cup (Chinaware)
2	83301	TX-3 保护罩 (金属)	TX-3 Shield Cup (Metal)
3	83200	TX-3 不锈钢罩	TX-3 Inside Cap
4	83401	TX-3 保护气体扩散器	TX-3 Shield Gas Diffuser
5	83400	TX-3 不锈钢筒体	TX-3 Tip Body
6	83004	TX-3 不锈钢筒体 O 形胶圈	TX-3 Tip Body O-ring
7	83201	TX-3 不锈钢筒体螺丝	TX-3 Tip Body Screw
8	83224	TX-3 导电嘴 2.4	TX-3 Tip, 2.4
8	83225	TX-3 导电嘴 2.4, 三孔	TX-3 Tip, 2.4, 3holes
8	83232	TX-3 导电嘴 3.2	TX-3 Tip, 3.2
8	83233	TX-3 导电嘴 3.2, 三孔	TX-3 Tip, 3.2, 3holes
8	83240	TX-3 导电嘴 4.0	TX-3 Tip, 4.0
8	83241	TX-3 导电嘴 4.0, 三孔	TX-3 Tip, 4.0, 3holes
8	83248	TX-3 导电嘴 4.8	TX-3 Tip, 4.8
8	83249	TX-3 导电嘴 4.8, 三孔	TX-3 Tip, 4.8, 3holes
9	83002	TX-3 导电嘴 O 形胶圈 (小)	TX-3 Tip O-ring S
10	83003	TX-3 导电嘴 O 形胶圈 (大)	TX-3 Tip O-ring B
11	83305	TX-3 大绝缘筒	TX-3 Insulator
12	83008	TX-3 大绝缘筒 O 形胶圈	TX-3 Insulator O-ring
13	83005	TX-3 大绝缘筒胶垫	TX-3 Insulator Gasket
14	83348	TX-3 对中块 (Φ4.8)	TX-3 Insulating Sleeve (Φ4.8)
15	83748	TX-3 钨极 (Φ4.8)	TX-3 Electrode (Φ4.8)
16	83648	TX-3 钨极夹 (Φ4.8)	TX-3 Collet (Φ4.8)
17	83600	TX-3 钨极夹套筒	TX-3 Collet Liner
18	83006	TX-3 钨极夹套筒 O 形胶圈 (下)	TX-3 Collet Liner O-ring (below)
19	83007	TX-3 钨极夹套筒 O 形胶圈 (上)	TX-3 Collet Liner O-ring (up)
20	83903	TX-3 枪帽	TX-3 Back Cap
21	83009	TX-3 枪帽 O 形胶圈	TX-3 Back Cap O-ring
22	83800	TX-3 枪柄 (胶木材质)	TX-3 Handle (Bakelite)
23	83200	TX-3 钨极限位塞规	TX-3 Electrode Setting Gauge

外形尺寸 (单位: mm)

Dimensions (Unit: mm)

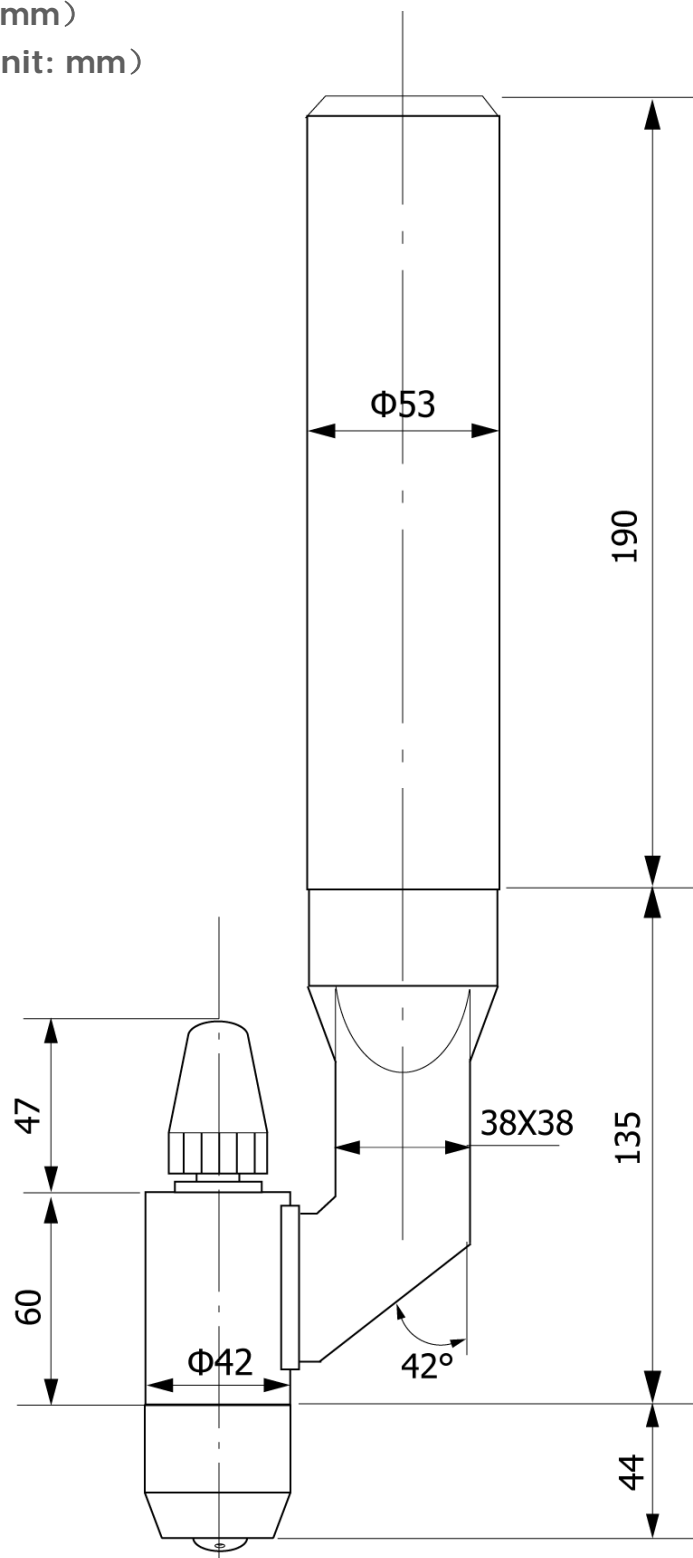

TONKS 三力易胜

TEL: 86-10-81454970 / 4970

FAX: 86-10-64421321

E-mail: support@tonksweld.com